



MODEL TEMPF-TP1/TP2-YT

MOBILE PUMP FILLER

GENERAL DESCRIPTION

The TUCS MOBILE PUMP FILLER is designed for the fast, gentle transfer of hot or cold product from one container to another. Fully tapered ports assure transfer without product damage. Single (-TP 1 up to 15 GPM) or dual barrel (-TP 2 up to 30 GPM) configurations are available.

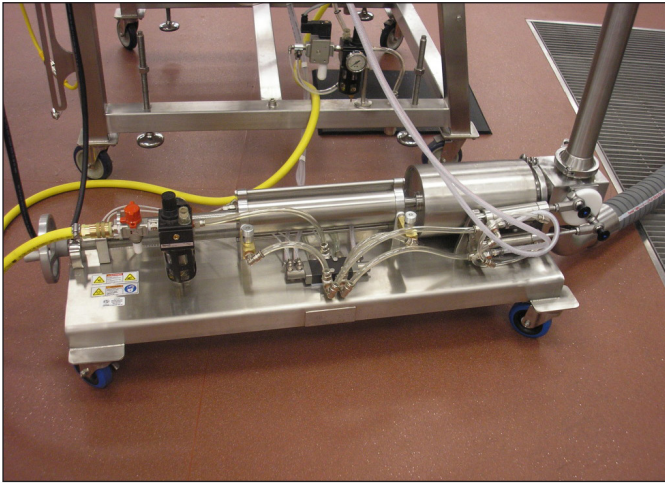

Tucs Mobile Pump Filler

CERTIFICATIONS

NSF/ANSI-169



TUCS Equipment, Inc.
755 County Road 18 S. • Princeton MN 55371
Phone 763-574-7475 Fax 763-574-7472
www.tucsequipment.com

ITEM NO.

PROJECT

QUANTITY

AIA NO.

CONSTRUCTION & FEATURES

All stainless-steel construction type 316L product contact surfaces, type 304L elsewhere ■ Engraved position scale for quick set up ■ Handle for easy movement of pump ■ Pneumatic flow control to regulate cycle speed ■ Furnished with air filter/lubricator/regulator ■ Foot Pedal

PUMP HEAD AND METERING BARREL

Exclusive tapered ports to eliminate product damage ■ Double arm activation of rotary valve ■ Rotary valve sized for hot fill (160°F-190°F fill temperatures) – other fill temperatures available(see chart on back before ordering) ■ Head block dairy clamp connections: 3" inlet, 2½" discharge ■ 6" diameter metering barrel – 136 oz. capacity ■ Stainless steel drive cylinder

OPTIONS INCLUDED

Two (2) sections of 3" dia. x 3" dia. x 3' long USDA approved food transfer inlet hose with dairy clamp fittings ■ 10' length of compressed air hose with quick disconnects ■ Spare Parts Kits ■ TEBK-cleaning brush kit

OPTIONS

- Conical food transport hoppers
- Vertical discharge nozzle (specify height)
- Single or multiple stroke transfers actuated by optional switch on handle
- Optional Riser Pipe (verify height and nozzle size prior to ordering)

MODEL TEMPF-TP1/TP2-YT

MOBILE PUMP FILLER

Scan this QR code with your smart phone to visit our website for more information.

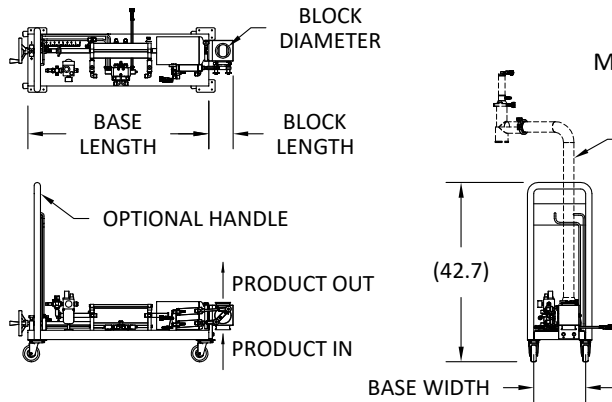

MODEL TEMPF-TP1-YT

MOBILE TRANSFER PUMP - SINGLE BARREL

OPTIONAL RISER PIPE
(VERIFY HEIGHT AND NOZZLE SIZE PRIOR TO ORDERING)

DIMENSIONS					
BLOCK SIZE (Y)	B	C	D	E	F
DIAMETER	2 3/4"	3"	3 1/2"	4"	4"
BLOCK LENGTH	3"	4"	5"	5"	6"
BASE WIDTH	6"	11"	12"	12"	12"
BASE LENGTH	24"	42"	43"	43"	43"

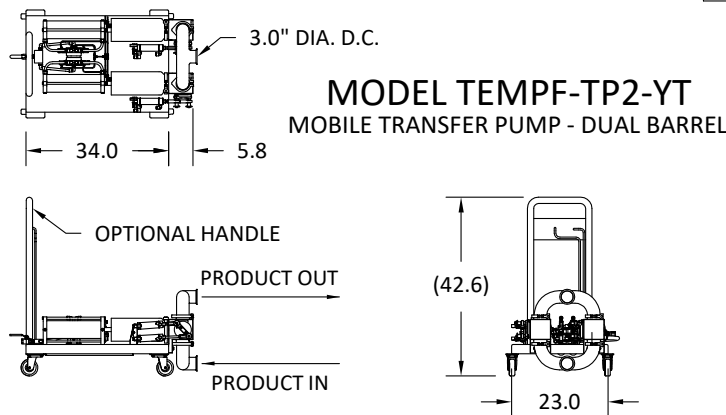

MODEL TEMPF-TP2-YT

MOBILE TRANSFER PUMP - DUAL BARREL

ROTARY VALVE TYPE		
SUFFIX (T)	DESCRIPTION	TEMP RANGE
CC	COLD COLD	30°F - 40°F
C	COLD	45°F - 65°F
R	ROOM	65°F - 90°F
W	WARM	90°F - 140°F
H	HOT	140°F - 185°F
HH	HOT HOT	185°F - 205°F

CONNECTIONS		
MODEL	DESCRIPTION	COMPRESSED AIR
TEMPF-TP1-YT	SINGLE BARREL PUMP	1/2" QD - 15 CFM @ 90 PSI
TEMPF-TP2-YT	DUAL BARREL PUMP	1/2" QD - 30 CFM @ 90 PSI

RECOMMENDED CLEARANCES	
RIGHT SIDE	12"
BACK	12"
LEFT SIDE	12"

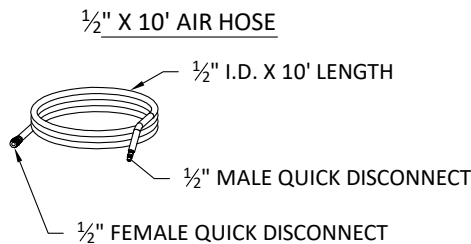

3.0" DIA. FLEXIBLE INLET HOSE - TEITP

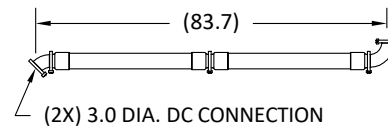

INCLUDED:

- TEITP - TWO (2) SECTIONS OF 3" DIA. X 3' LONG USDA APPROVED FOOD TRANSFER INLET HOSES WITH DAIRY CLAMPS, GASKETS AND ELBOWS
- 10' LENGTH OF COMPRESSED AIR HOSE WITH QUICK DISCONNECTS
- SPARE PARTS KIT
- TEBK - CLEANING BRUSH KIT

11/4/2020

Due to continuous improvements, specifications subject to change without notice.

© 2020 TUCS Equipment. All Rights Reserved. Printed in the USA.