



## MODEL TEMPF-ECONO-YT

MOBILE PUMP FILL STATION

### GENERAL DESCRIPTION

The TUCS MOBILE PUMP FILLER provides rapid and precision metering of pumpable products from a kettle into casings or pouches. Hermetically sealed lay-flat pouches with a heat sealer. It can also transfer products between vessels or to load vessels with pumpable products. Repeatable volumes are adjusted utilizing a precision lead screw.



TEMPF-ECONO-YT (SHOWN ATTACHED TO EXISTING KETTLE)

**CERTIFICATIONS**  
NSF/ANSI-169



**TUCS Equipment, Inc.**  
755 County Road 18 S. • Princeton MN 55371  
Phone 763-574-7475 Fax 763-574-7472  
[www.tucsequipment.com](http://www.tucsequipment.com)

ITEM NO.

PROJECT

QUANTITY

AIA NO.

### CONSTRUCTION & FEATURES

All stainless-steel construction type 316L product contact surfaces, type 304L elsewhere ■ Adjustable work surface to support pouch/casing during fill sequence ■ Engraved position scale for quick setup ■ Foot pedal initiation of pump sequence and heat sealer ■ Operator selection of single cycle or continuous (for product transfer or cleaning) and for actuating heat sealer ■ Pneumatic flow control to regulate cycle speed ■ Furnished with air filter/lubricator/regulator

### PUMP HEAD AND METERING BARREL

Exclusive tapered ports to eliminate product damage ■ Double arm activation of rotary valve ■ Rotary valve sized for hot fill (160°F–190°F fill temperatures) – other fill temperatures available (see chart on back before ordering) ■ Head block dairy clamp connections: 3-inch inlet, 2½-inch discharge ■ 6-inch Dia. metering barrel – 136 oz. capacity ■ Quick disconnect product metering plunger adjustable from 32 oz. to 136 oz. ■ Stainless steel drive cylinder ■ TEBK Brush Cleaning Kit

### DISCHARGE NOZZLE

2-inch fill nozzle with heat shield ■  
Air-activated plunger for dripless cut-off

### SEALING

The pedestal post mounted electric single band heat sealer allows operators to create lay-flat pouches that chill quicker and are easier to store. Heat sealer with foot pedal activation ■ On/Off Switch ■ Adjustable seal time and temperature

### OPTIONS

- Two (2) sections of 3" diameter x 3'-long USDA approved food transfer inlet hose with dairy clamp fittings
- 10' length of compressed air hose with quick disconnects

# MODEL TEMPF-ECONO-YT

MOBILE PUMP FILL STATION

Scan this QR code with your smart phone to visit our website for more information.



## TUCS MODEL TEMPF-ECONO-YT MOBILE PUMP FILL STATION

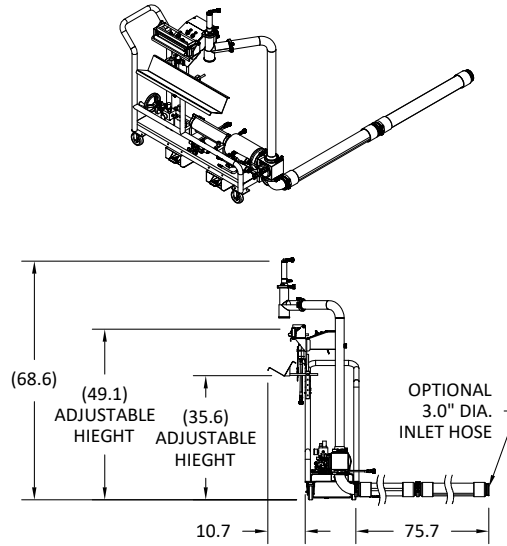
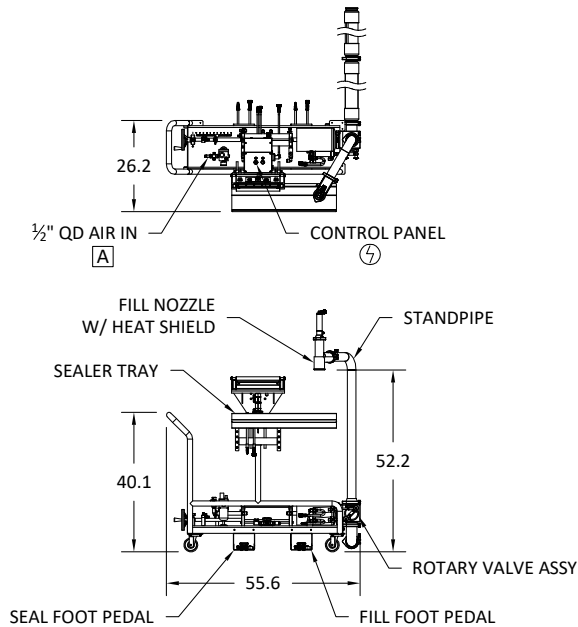

DIMENSIONS					
BLOCK SIZE (Y)	B	C	D	E	F
DIAMETER	2 1/4"	3"	3 1/2"	4"	4"
BLOCK LENGTH	3"	4"	5"	5"	6"
BASE WIDTH	6"	11"	12"	12"	12"
BASE LENGTH	24"	42"	43"	43"	43"

ROTARY VALVE TYPE		
SUFFIX (T)	DESCRIPTION	TEMP RANGE
CC	COLD COLD	30°F - 40°F
C	COLD	45°F - 65°F
R	ROOM	65°F - 90°F
W	WARM	90°F - 140°F
H	HOT	140°F - 185°F
HH	HOT HOT	185°F - 205°F

UTILITIES		
SYM	DESCRIPTION	UTILITY CONNECTION
A	COMPRESSED AIR	1/2" QUICK DISCONNECT - 15 CFM @ 90 PSI
⚡	ELECTRICAL	6.0 FLA @ 110 VAC W/ 3 PRONG CORD

RECOMMENDED CLEARANCES	
RIGHT SIDE	12"
BACK	12"
LEFT SIDE	12"

1/2" X 10' AIR HOSE (OPTION)

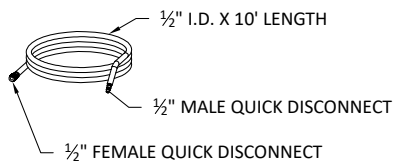

3.0" DIA. FLEXIBLE INLET HOSE - TEITP (OPTION)

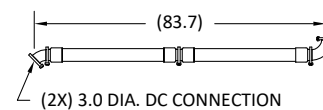

INCLUDED:

- SPARE PARTS KIT
- FILL NOZZLE (VARIETY OF SIZES AVAILABLE)
- TEBK - CLEANING BRUSH KIT

OPTIONS:

- TEITP - TWO (2) SECTIONS OF 3" DIA. X 3' LONG USDA APPROVED FOOD TRANSFER INLET HOSES WITH DAIRY CLAMPS, GASKETS AND ELBOWS
- 10' LENGTH OF COMPRESSED AIR HOSE WITH QUICK DISCONNECTS