



MODEL TEMPF-30-HOP

MOBILE 30-GALLON HOPPER CART

GENERAL DESCRIPTION

The TUCS MOBILE 30 GALLON HOPPER CART can produce from 7 oz. to 38 oz. and readily accommodates wet products. Volumetric filling is accomplished by an onboard, highly accurate, repeatable, and gentle piston pump.

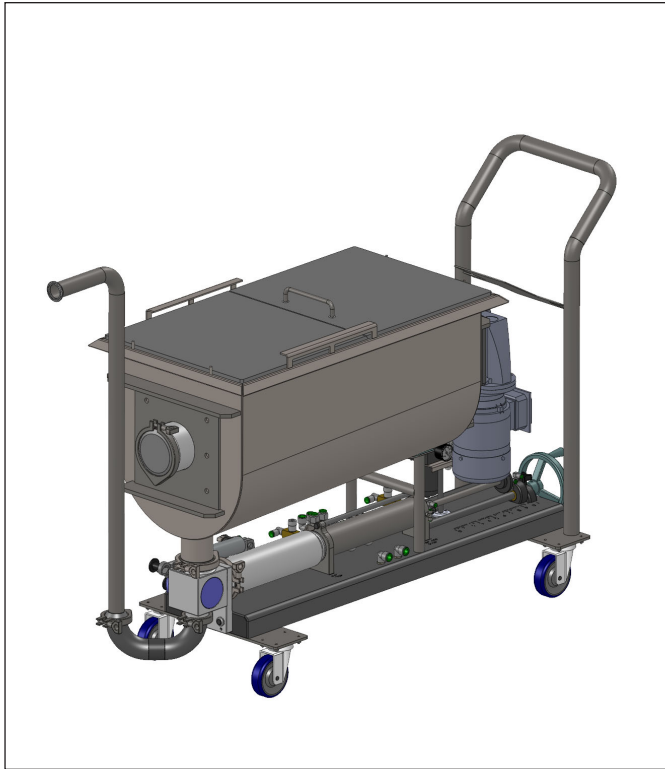

TEMPF-30-HOP MOBILE HOPPER CART (RENDER)

CERTIFICATIONS

ANSI/UL-197, NSF/ANSI 4-2007e



TUCS Equipment, Inc.
755 County Road 18 S. • Princeton MN 55371
Phone 763-574-7475 Fax 763-574-7472
www.tucsequipment.com

ITEM NO.

PROJECT

QUANTITY

AIA NO.

CONSTRUCTION & FEATURES

All stainless-steel construction type 316L product contact surfaces, type 304L elsewhere

FILL NOZZLE

Fill nozzle height 42" above finished floor to fill containers on top of 36" table. (Verify before ordering)

- Drip-less cut-of prevents dripping between containers
- 1½" nozzle sized for 1" particulates

VOLUMETRIC PISTON PUMP

Standard C head block metering barrel quickly adjustable from 7 ounces to 38 ounces ▪ Compressed air operation. No electrical connections required for pump

OPTIONS

- Cold fill pump accessories
- Custom barrel and fill nozzle sizes for larger capacities per pump stroke
- 30" long flexible dispensing hose in lieu of riser pipe with fill nozzle
- Other nozzle sizes available

MODEL TEMPF-30-HOP

MOBILE 30-GALLON HOPPER CART

Scan this QR code with your smart phone to visit our website for more information.



TUCS MODEL TEMPF-30-HOP PUMP CART WITH 30 GALLON HOPPER

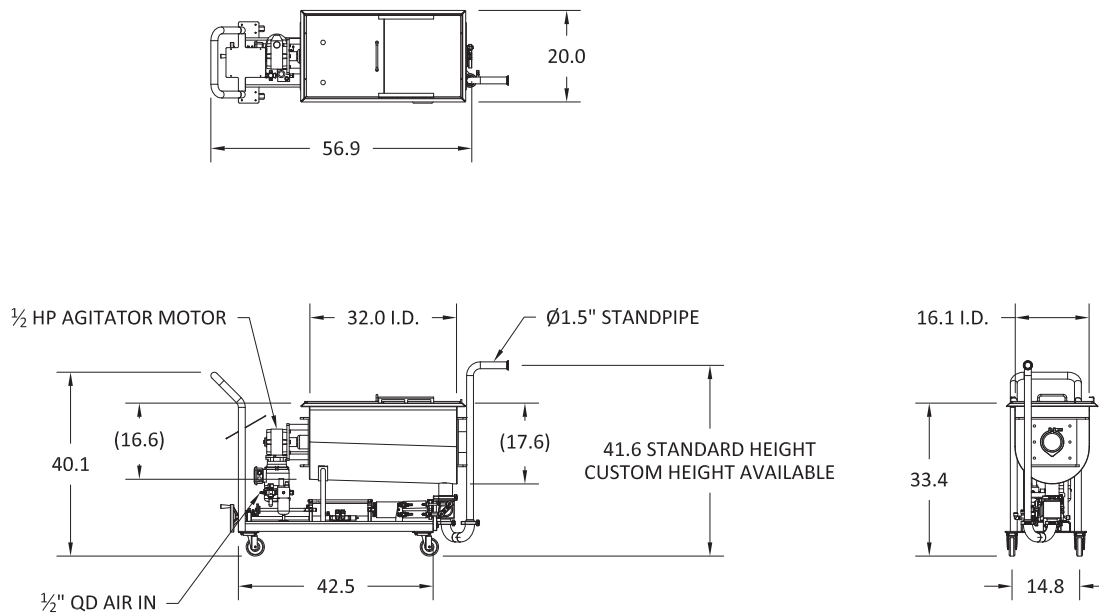

UTILITIES	
DESCRIPTION	UTILITY CONNECTION
COMPRESSED AIR	1/2" QUICK DISCONNECT - 15 CFM @ 90 PSI
ELECTRICAL	3.0 FLA @ 120 V/1 PH/60 Hz

RECOMMENDED CLEARANCES	
RIGHT SIDE	12"
BACK	12"
LEFT SIDE	12"

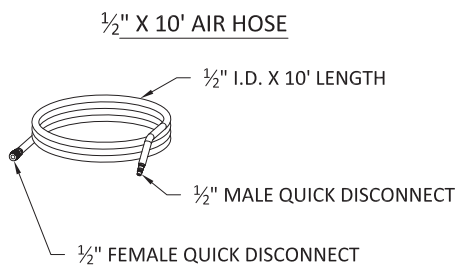

INCLUDED:

- Ø1 1/2" FILL NOZZLE (ALTERNATE SIZES AVAILABLE)
- 12' CORD W/ L5-15P, WATER TIGHT, 15A, 120V, 1PH, 3 POLE, 3 WIRE PLUG (CONNECTING L5-15R FEMALE RECEPTACLE INCLUDED)
- 10' LENGTH OF COMPRESSED AIR HOSE WITH QUICK DISCONNECTS
- SPARE PARTS KIT
- TEBK - CLEANING BRUSH KIT