



EQUIPMENT, INC

FOOD SERVICE LINE OF QUALITY PRODUCTS

Item No. _____

MODEL: THPT-HS-x
BASIC HORIZONTAL KETTLE WITH AGITATOR AND VARIABLE SPEED DRIVE

AIA 11400 FOOD SERVICE EQUIPMENT



STANDARD FEATURES

- Horizontal "Paddle Wheel" Agitator provides uniform blending of pumpable foods...
Excellent heat transfer by using a semi-cylinder base and a rectangular top section...
Low working height and minimum total need for floor space...
Door Safety Interlocks installed and Factory tested
Stainless Steel Valve Box installed and Factory Tested

BASIC AGITATOR

- While thoroughly and gently mixing at 0-18 RPM, the removable food grade scrapers keep the jacketed walls clean...
Variable speed drive is provided by an electrical exterior mounted right-angle drive...
Agitator assembly is easily removable from the kettle without using tools...

BASIC KETTLE

- The completed unit is an ASME certified pressure vessel for 100 PSIG working pressure...
All interior corners are radiused for easy cleaning and 3" Tri-clamp bottom outlet is connected to a 3" flush mounted drop down pneumatically operated discharge (fail Safe) Valve

SCRAPERS



3" DISCHARGE



The Kettle is U.S.D.A accepted & F.D.A. compliant. Unit is A.S.M.E. Shop inspected and stamped.

Consultant and Contractor Approvals:



EQUIPMENT, INC

5301 Industrial Blvd. NE Suite 200
Fridley, MN 55421

Phone: (763) 574-7475
Fax: (763) 574-7472
Email: martytucs@tucsequipment.com

MODEL: THPT-HS-x

BASIC HORIZONTAL KETTLE WITH AGITATOR

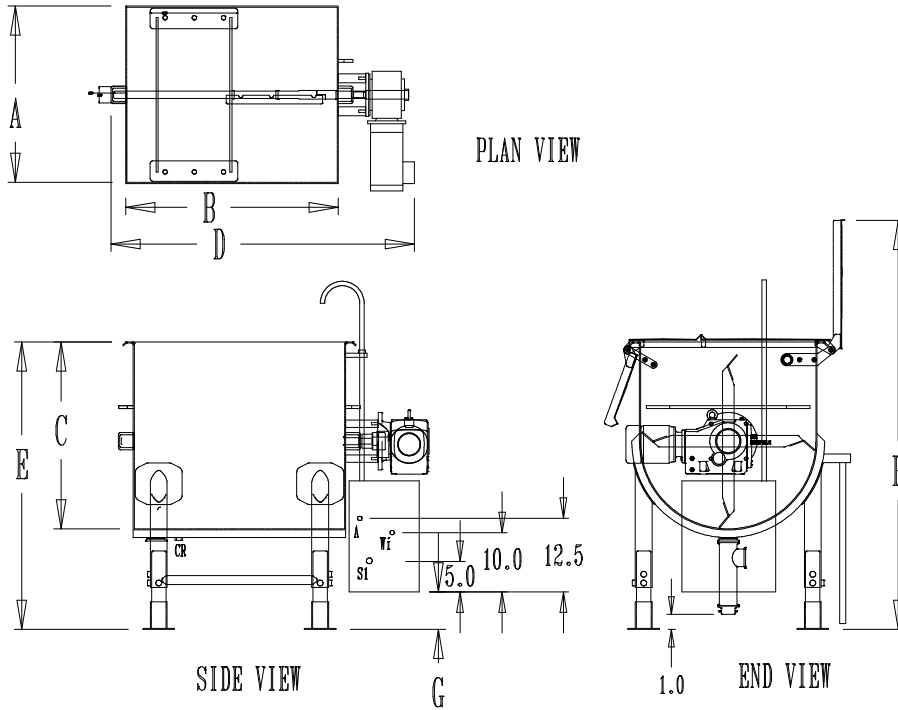

NOTE: See separate spec sheet showing integrated kettle c/w utility control box, cable and control panel for additional details.

MODEL	WORK CAP.	TANK CAP.	A	B	C	D	E	F	G	MOTOR HP
THPT-HS-60	62	71	24	28	27	42	48	60	6	1 HP
THPT-HS-100	100	110	28	34	30.5	48	48	62	6	1 HP
THPT-HS-150	153	164	30	44	32	58	48	64	6	1 HP
THPT-HS-200	201	214	33	48	35	62	52	68.5	6	1-1/2 HP
THPT-HS-300	300	318	38	54	40	68	55	78	6	2 HP
THPT-HS-400	408	429	42	60	44	74	59	84	6	3 HP

UTILITY REQUIREMENTS

S1= HI-PRESSURE
STEAM INLET
100 PSI
1" NPT - 60,100,150 Gal
1-1/2" NPT-200,300 Gal
2" NPT- 400 Gal

So= CONDENSATE
RETURN
1" NPT- 60,100,150 Gal
1-1/2" NPT 200-400 Gal

Wi = Water Fill Inlet
R = Relief Valve
A = Air Inlet, 1/4 NPT,80 psi, clean, dry

E = Electricity
208V 3 phase, See above
T = Temperature Sensor

MINI SPECIFICATION

Shall be a TUCS MODEL THPT-HS-___, Cook /Chill STATIONARY MIXER KETTLE ___gallons. Electrically driven horizontal agitator; variable mixer, Speed 0-18 RPM. Steam jacket is rated to 100 psi. Adjustable legs. Pneumatic draw off valve is flush mounted. Swivel water faucet. , "with add-on" button. Jacket Relief Valve. Temperature Probe for time / temperature chart recording. Emergency shutoff. Electro-polished inside. No.4 finish on all other surfaces. Type 316L on all food contact surfaces. Delron scraper blades. Integrated Valve Box.

OPTIONS

- DS—Volume Dip Stick in 5 Gal. Increments
- PL—Grated work platform (attached to kettle), 12" Tall, 16" and 20" wide (detachable)

JW—Jacket Water Cooling Package



EQUIPMENT, INC

5301 Industrial Blvd. NE Suite 200
Fridley, MN 55421

Phone: (763) 574-7475
Fax: (763) 574-7472
Email: martytucs@tucsequipment.com